

Capítulo 8 (Base de conducción 2)

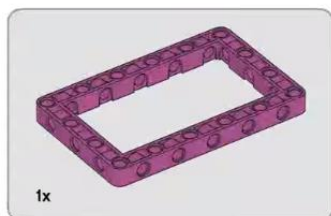

Consta de dos partes:

Base de conducción

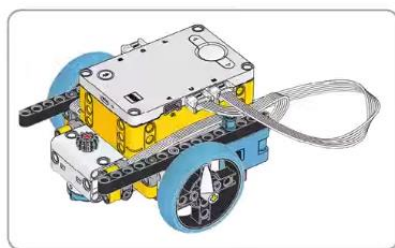
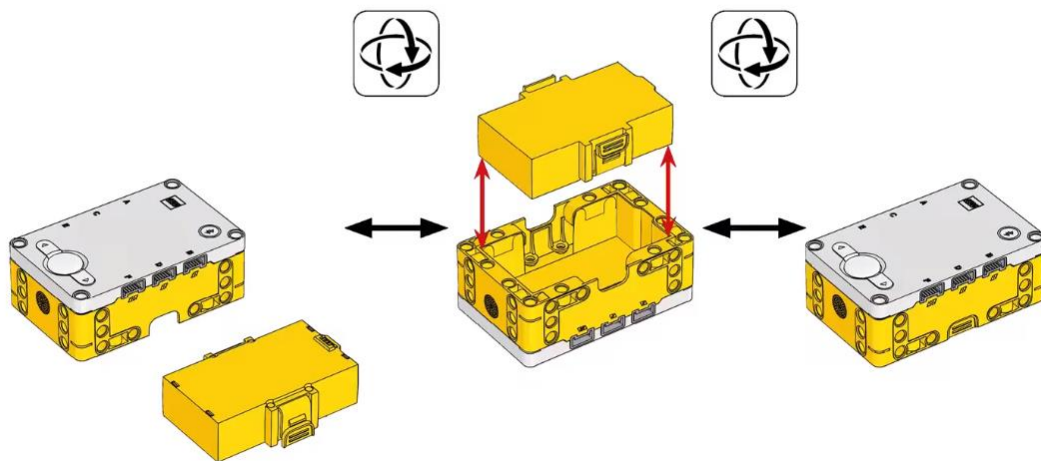

1

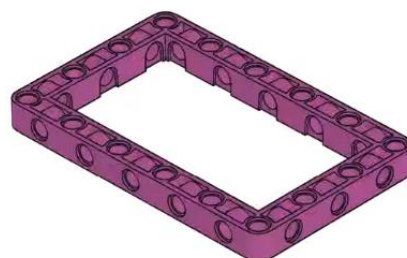



2

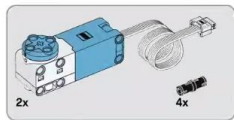
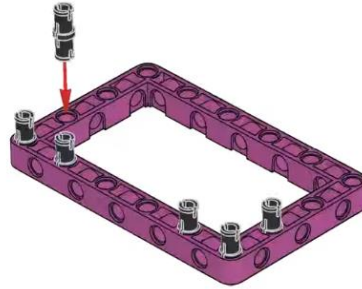

3

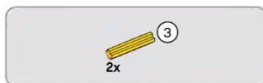
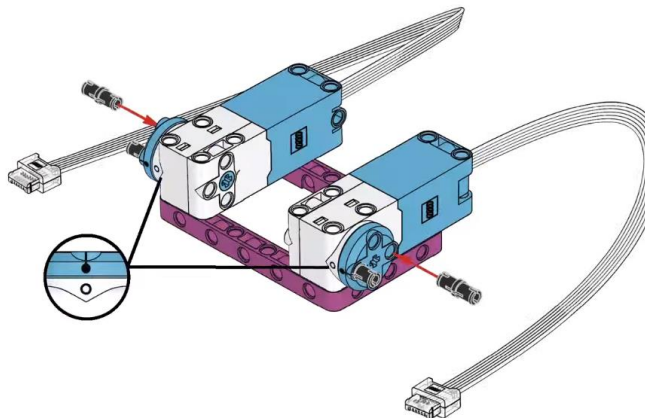

4

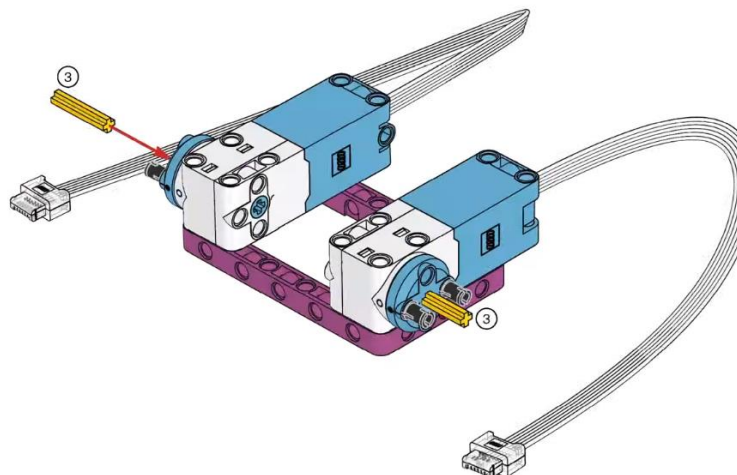



5

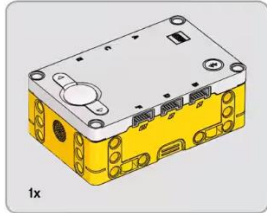
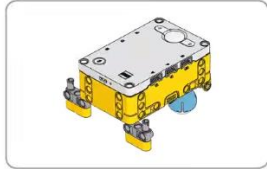
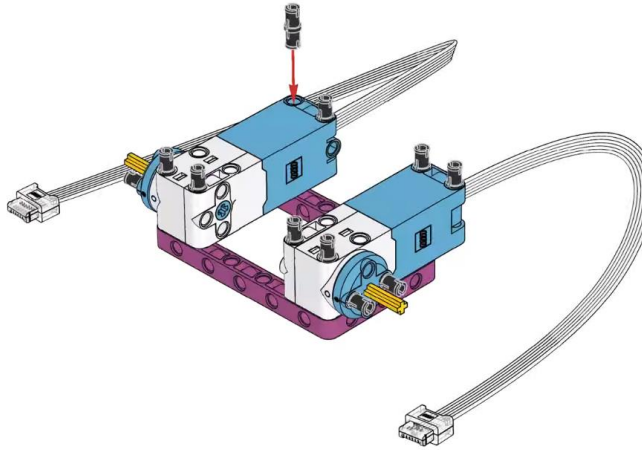

6

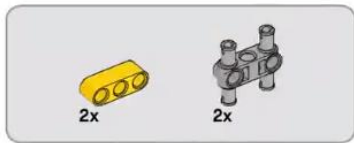
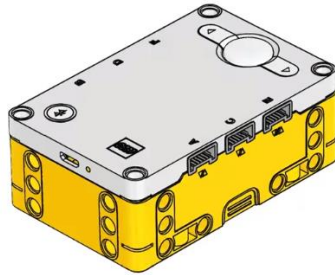

7

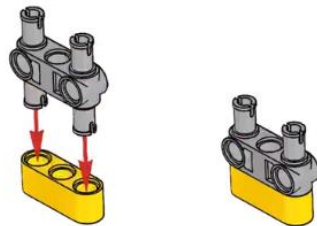

8

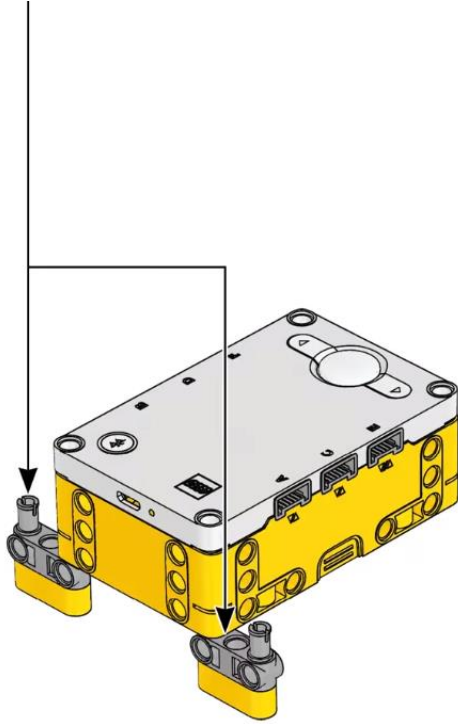

9

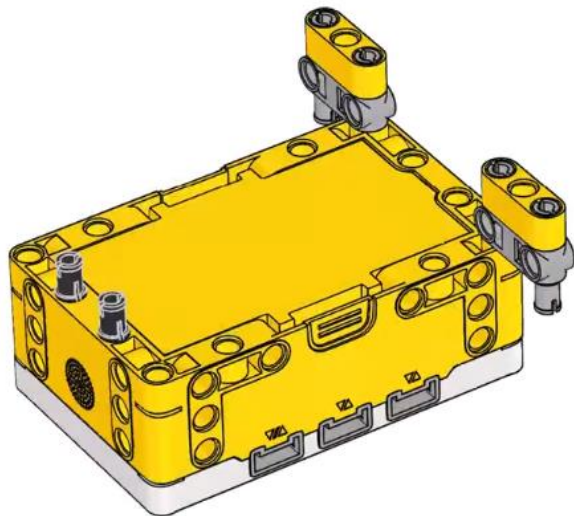

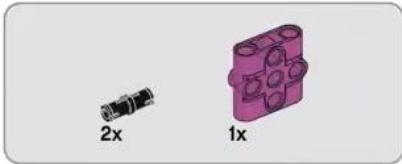

10

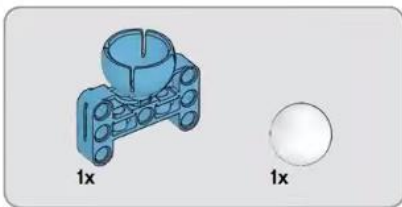
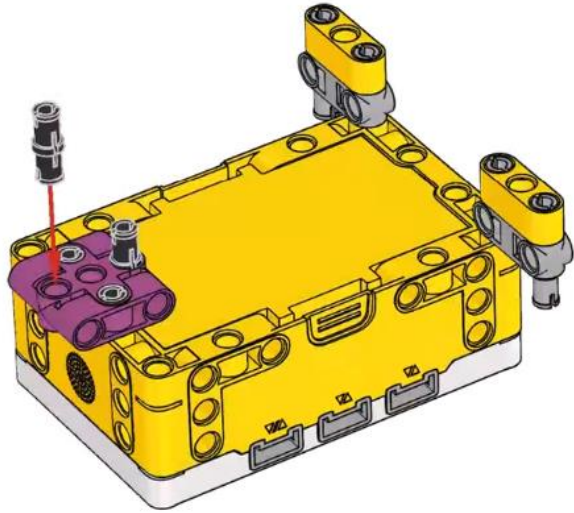

11

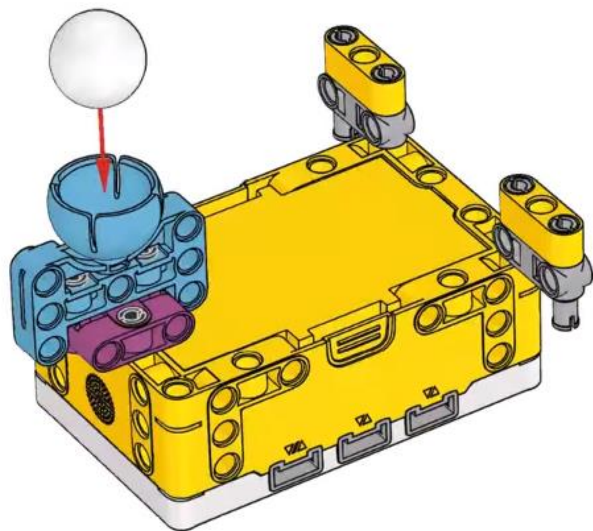

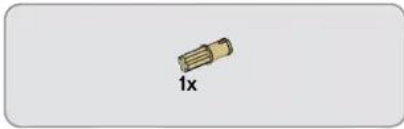

12

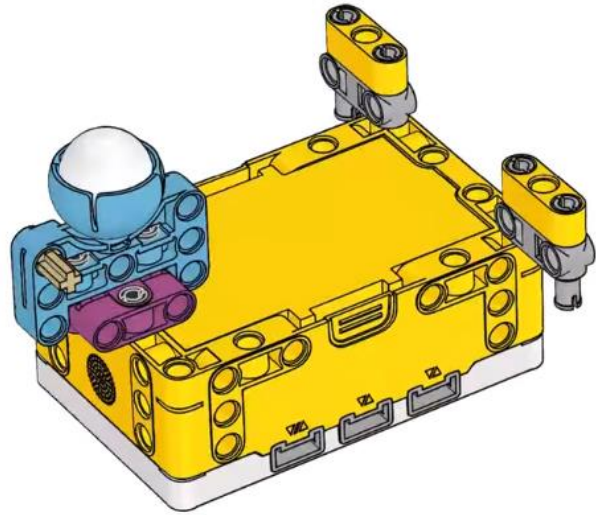

13

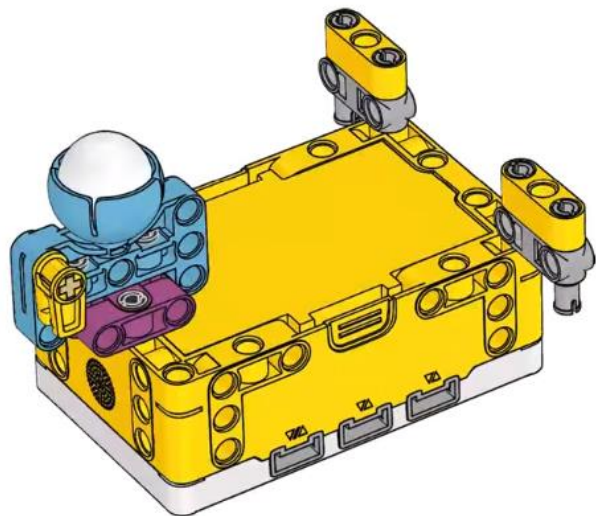

14

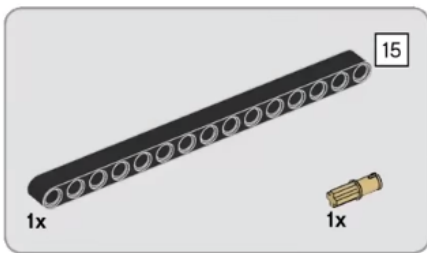
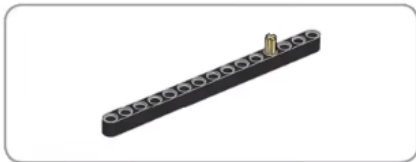
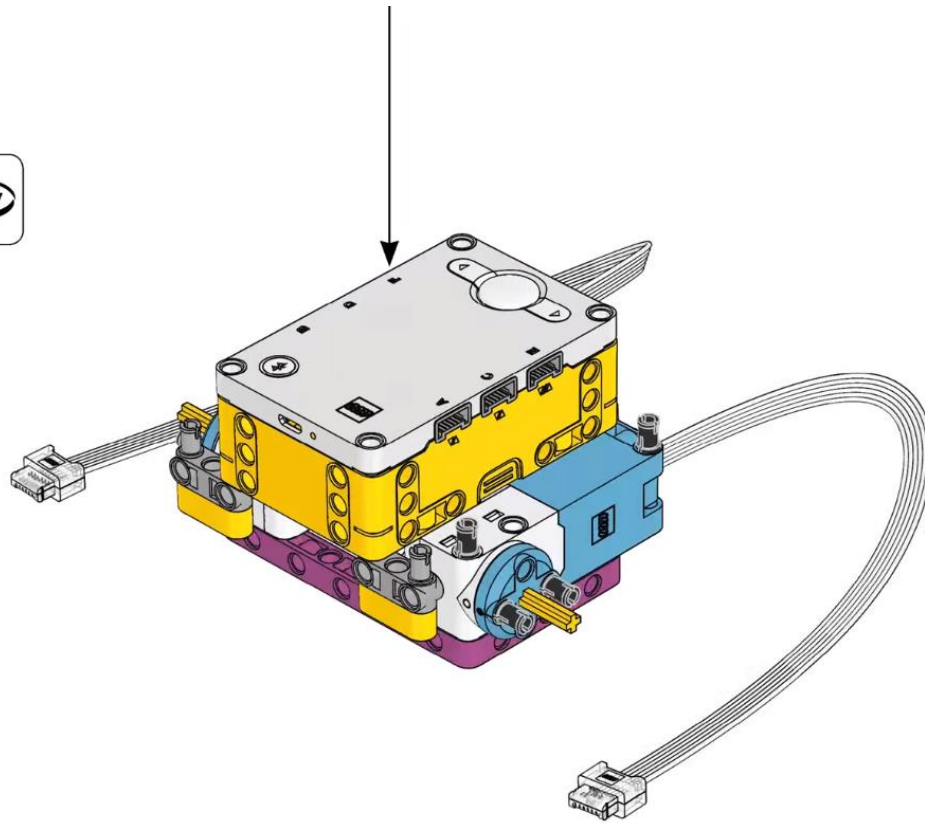

15

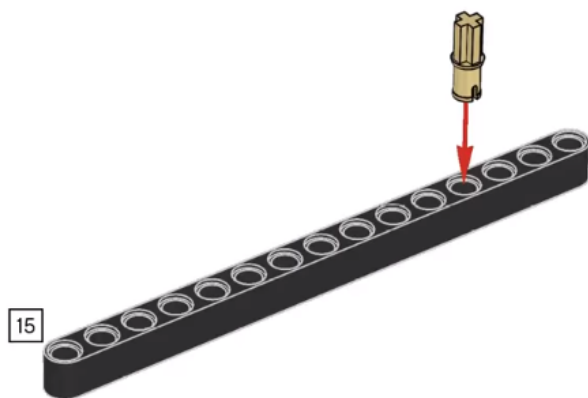

16

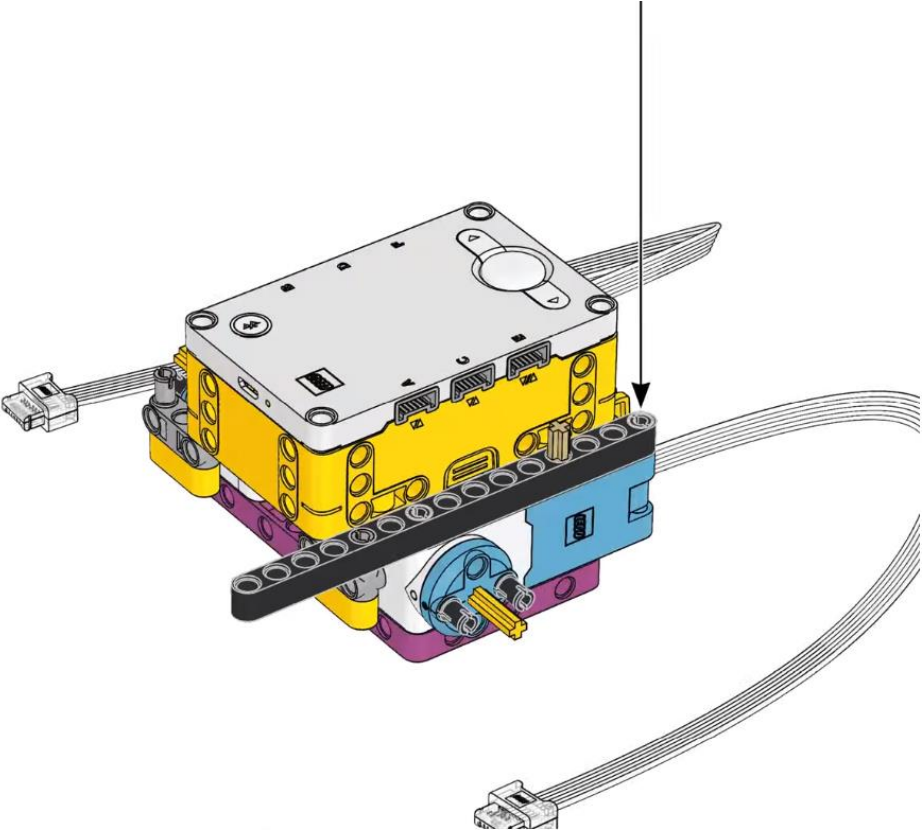

17

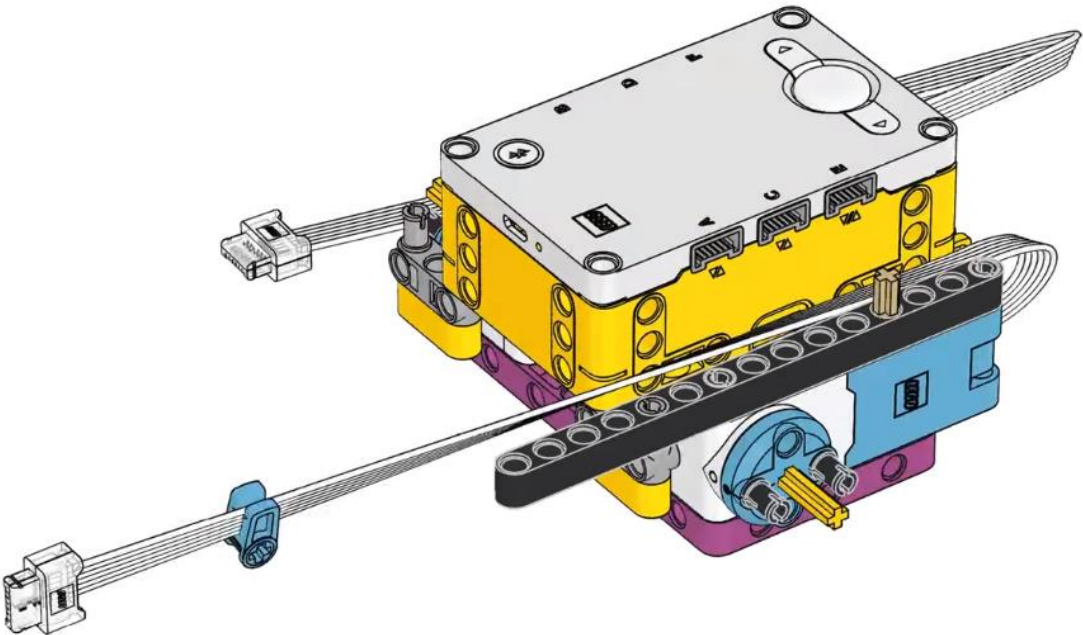

18

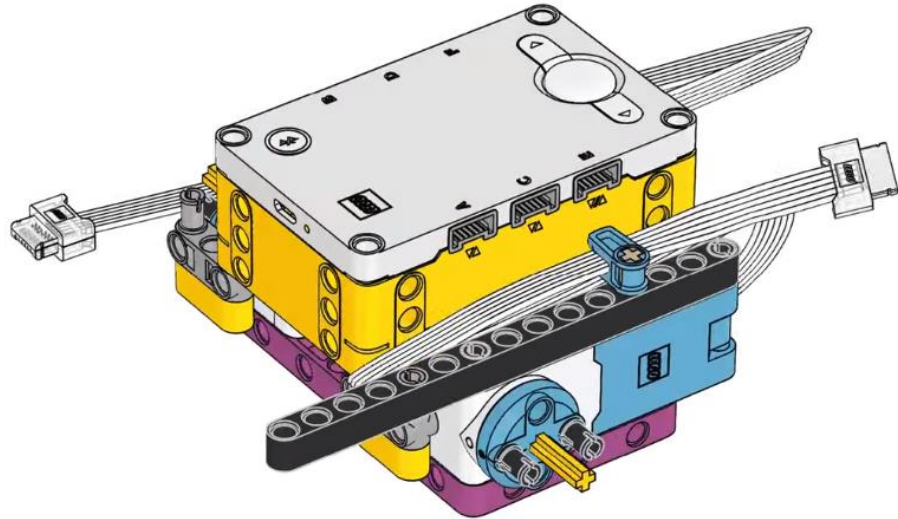

19

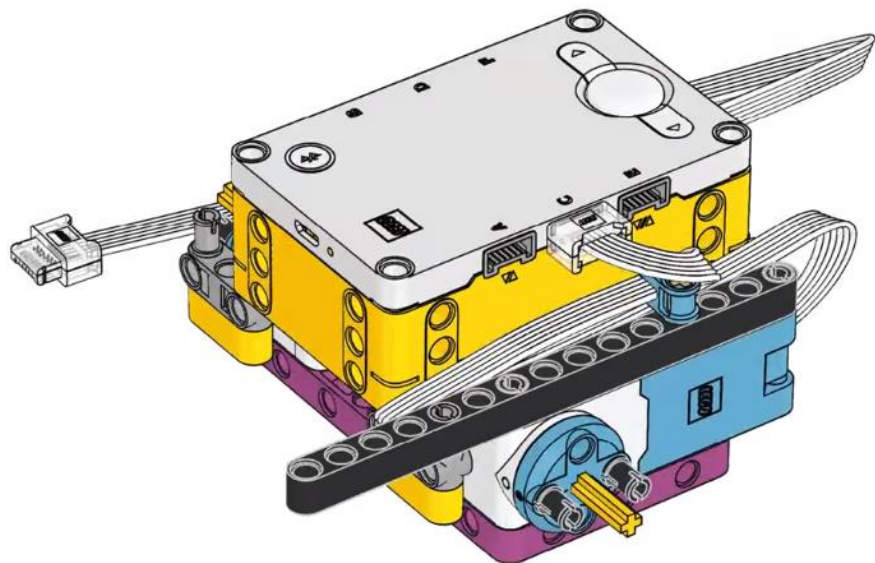



20

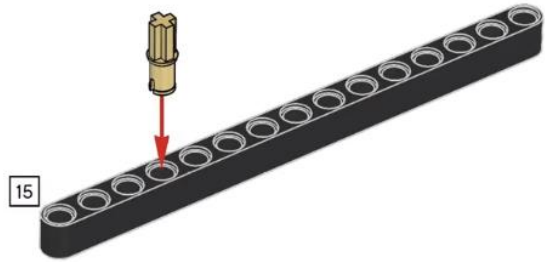

21

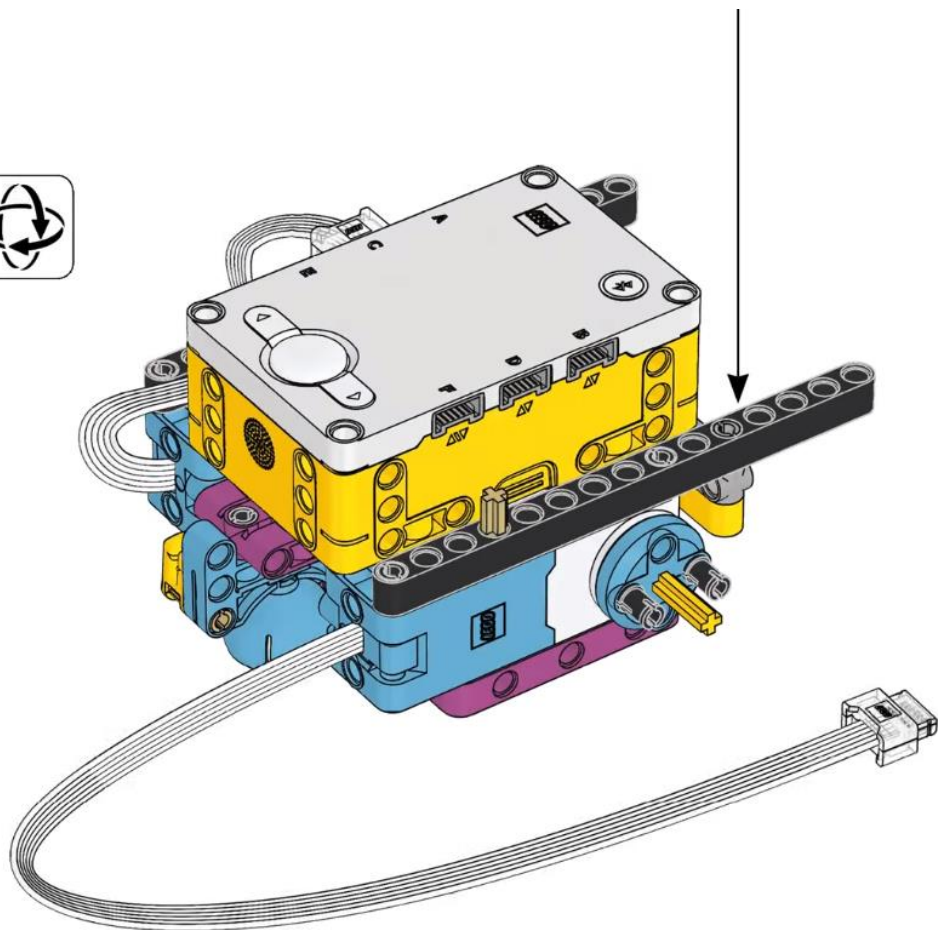



22

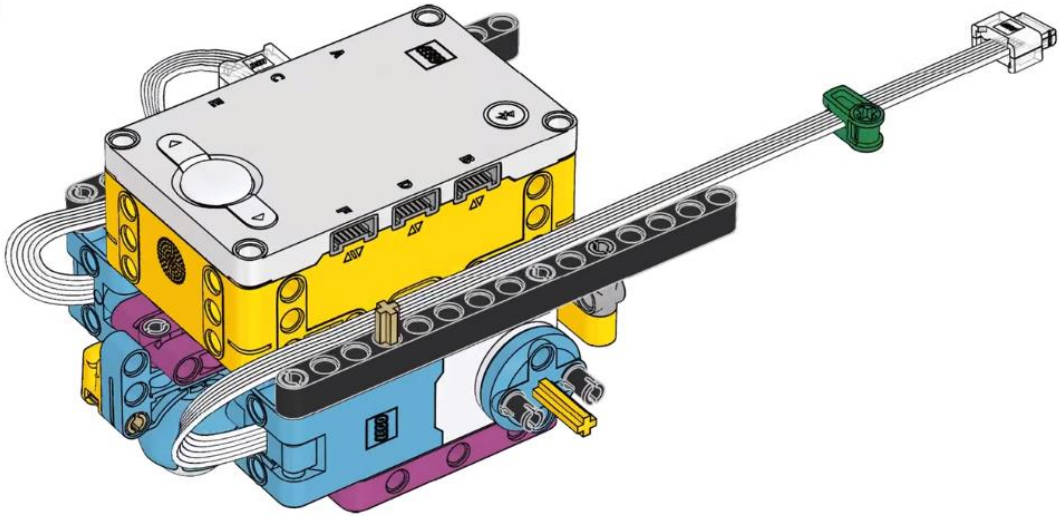

23

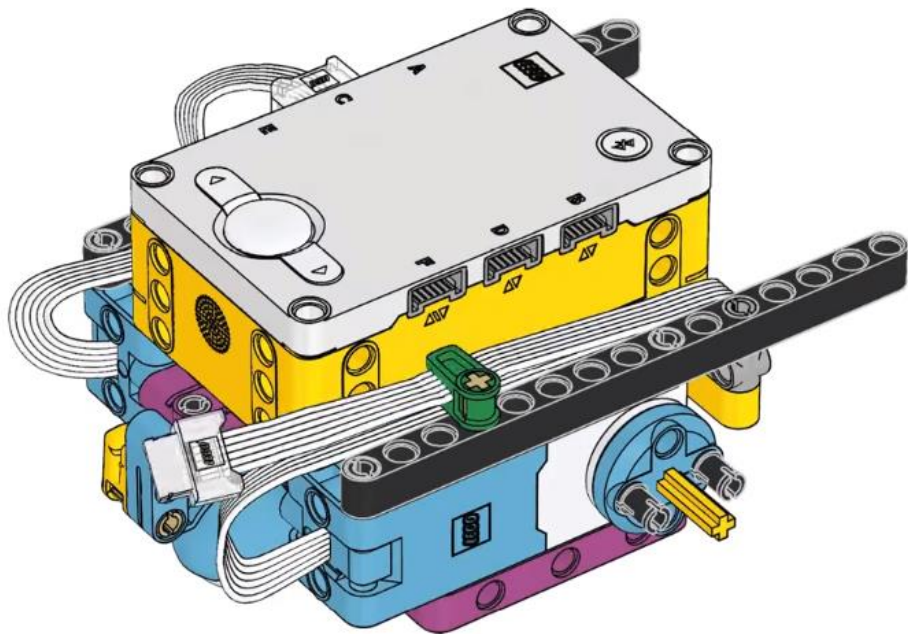

24

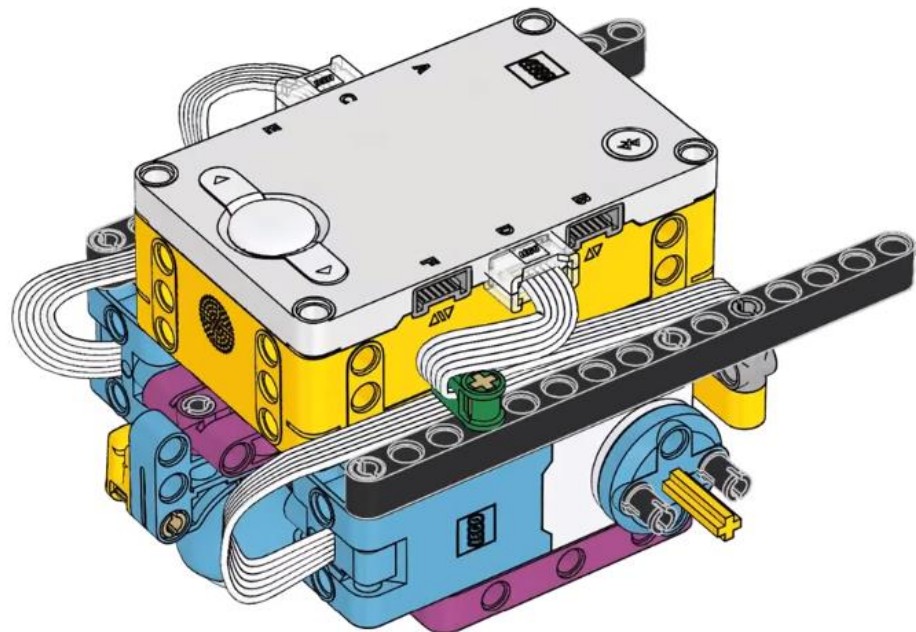

25

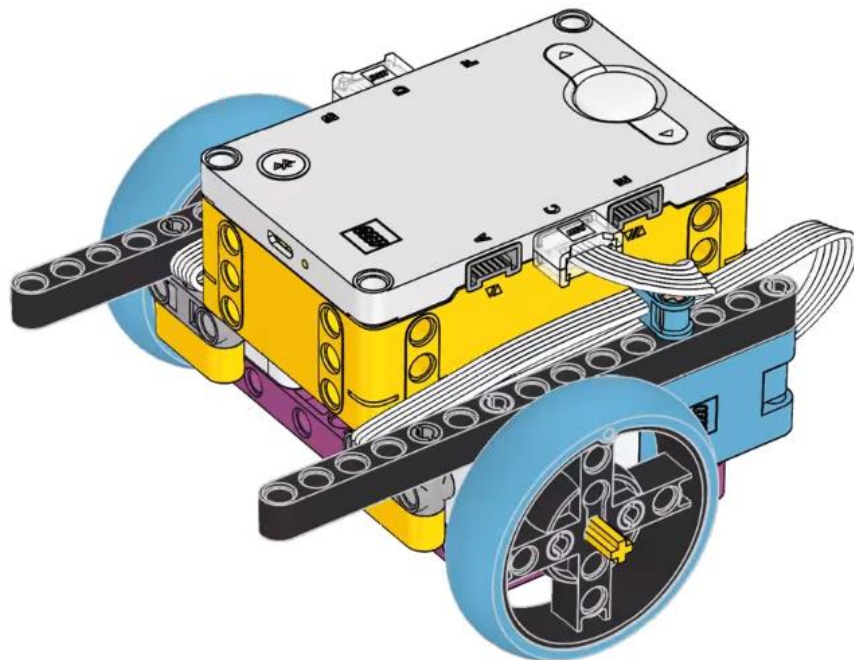

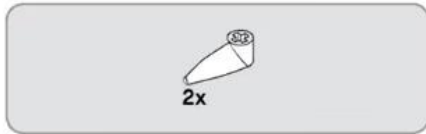

26

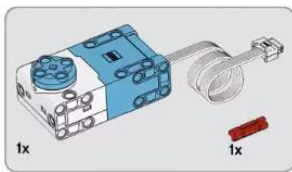
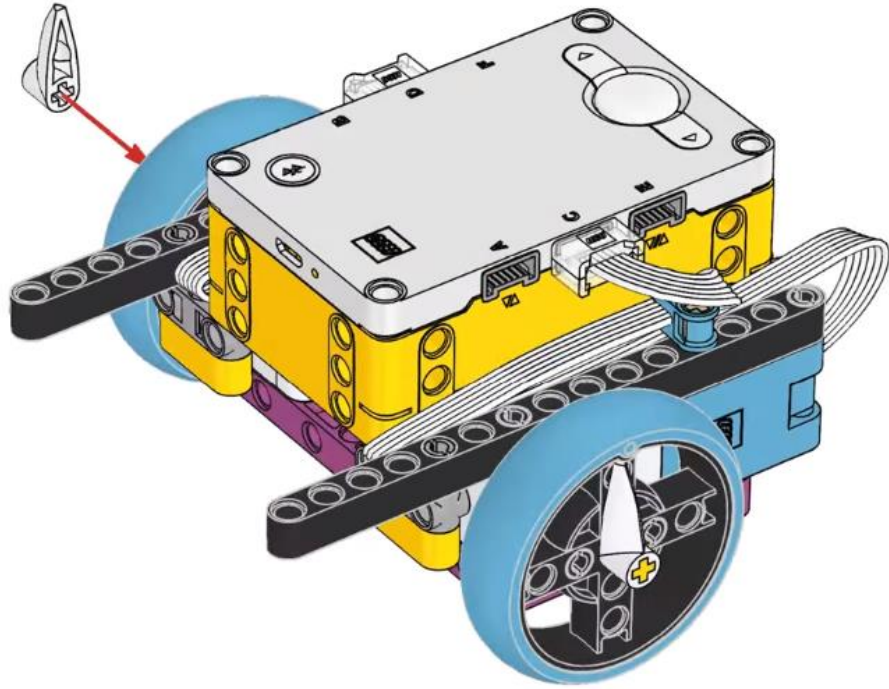

27

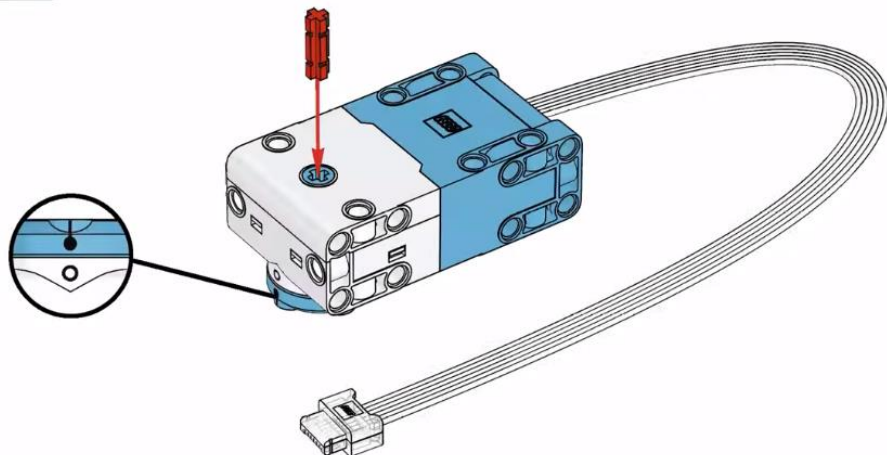



28

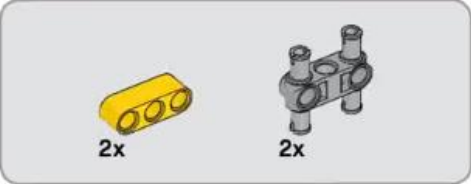
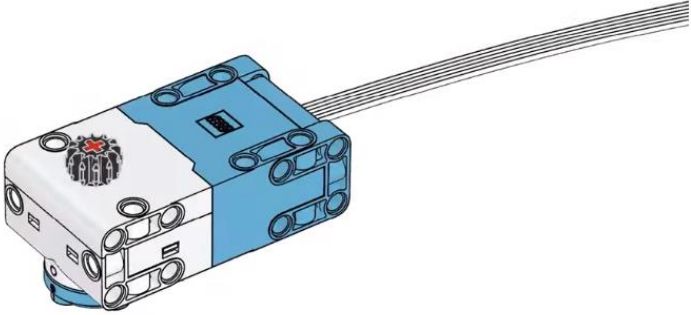

29

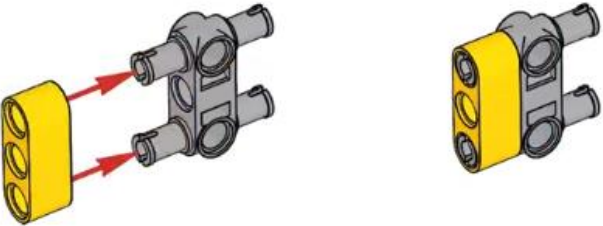



30

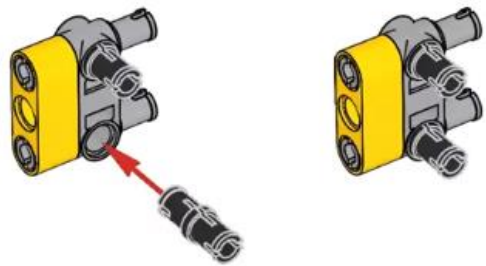

31

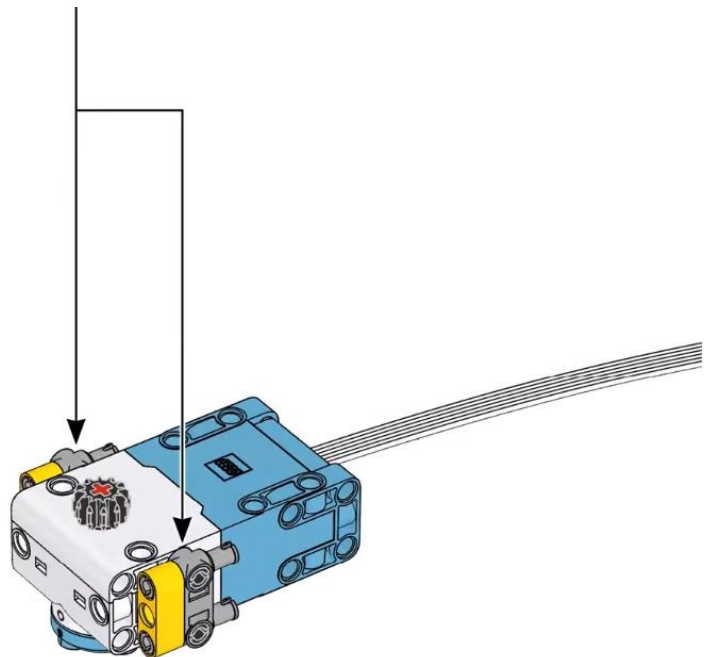

32

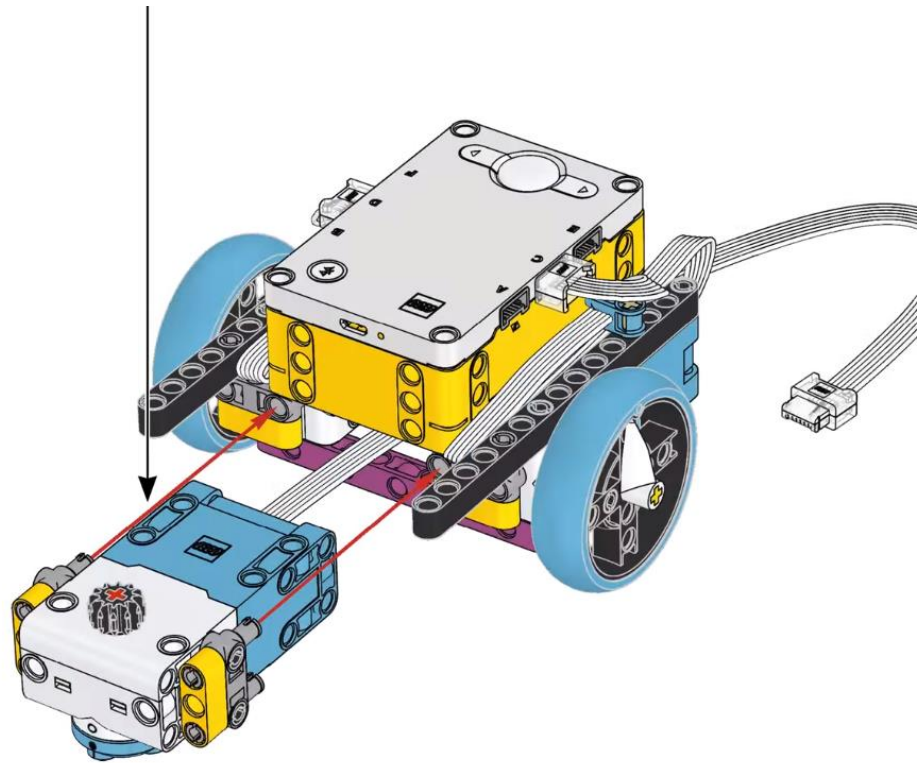

33

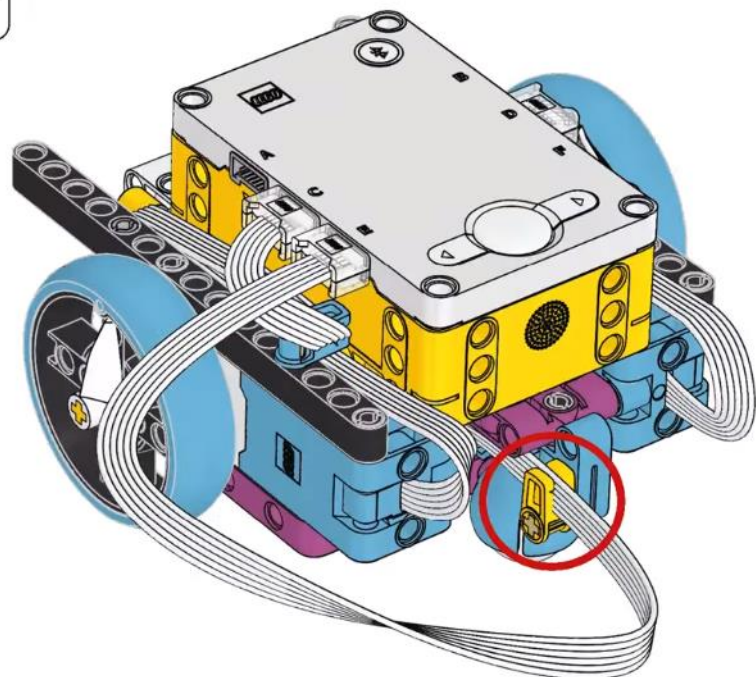

34

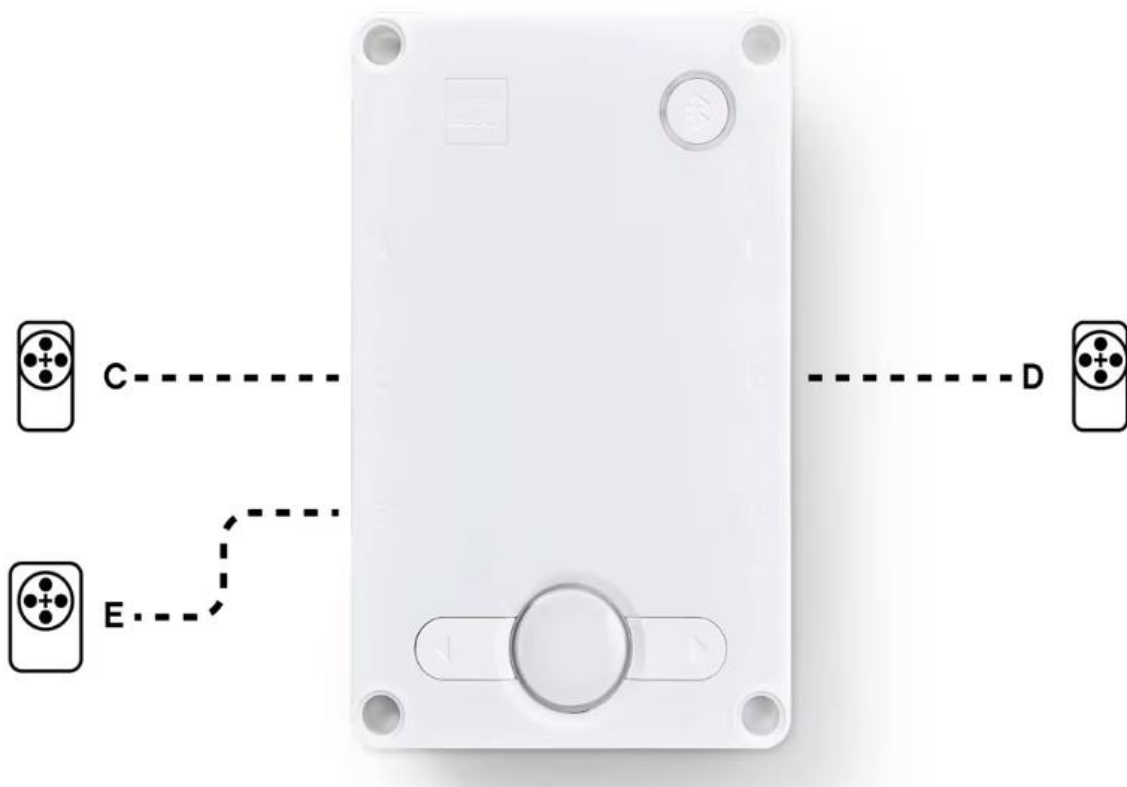
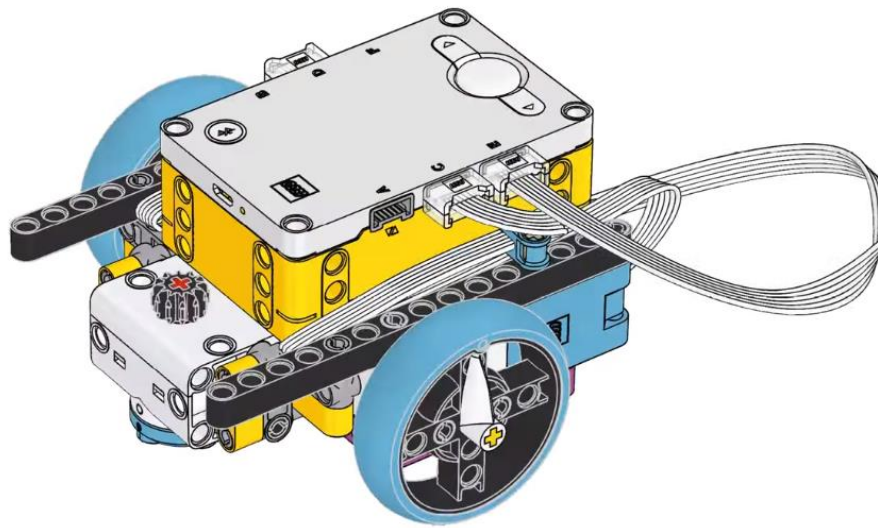

Herramientas y accesorios

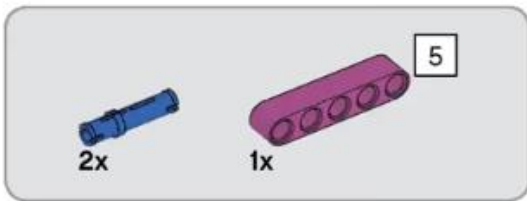
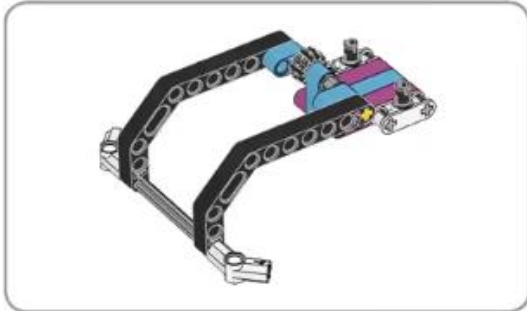
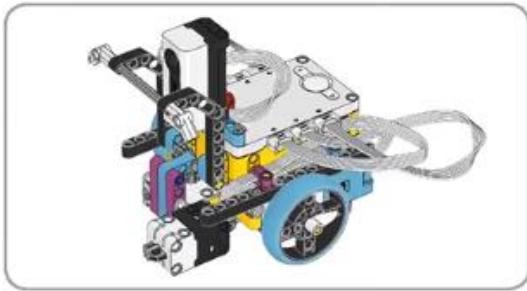

1

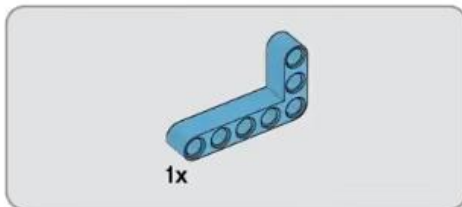
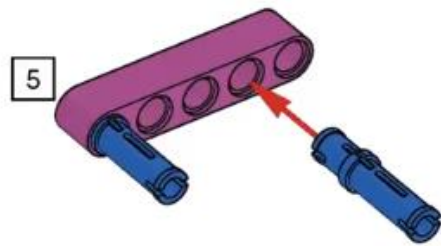

2

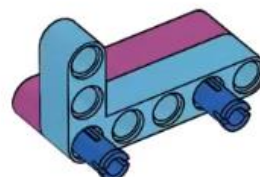

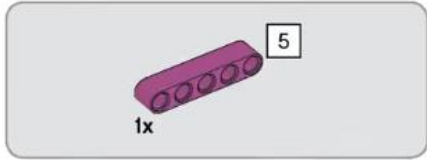

3

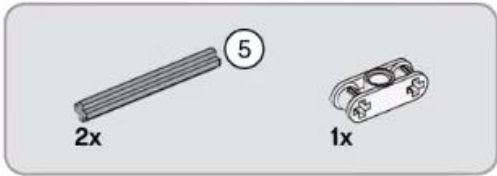
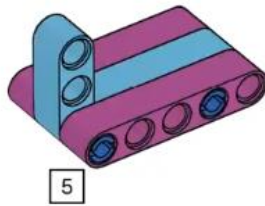

4

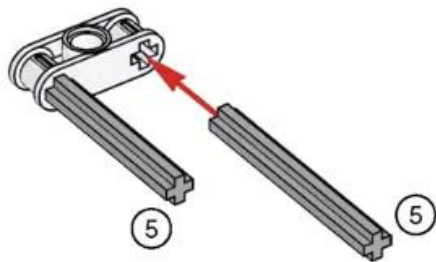

5

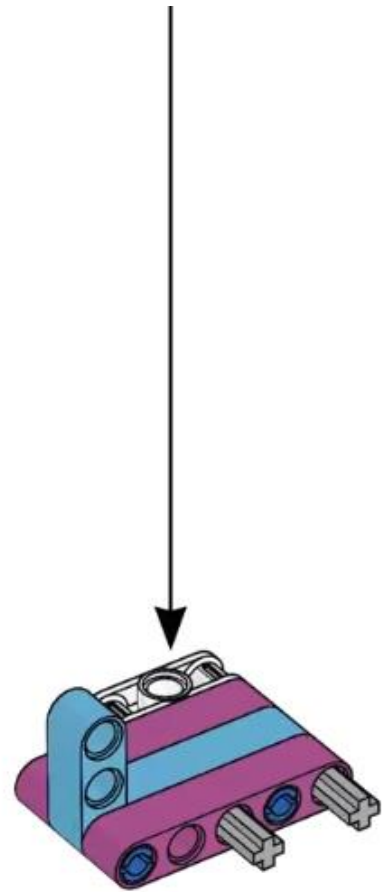

6

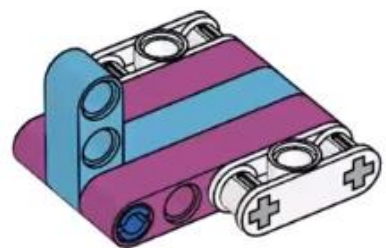



7

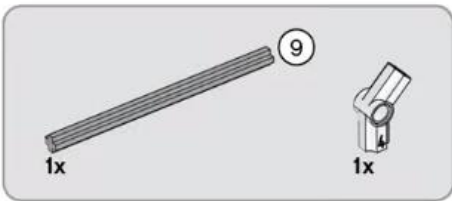
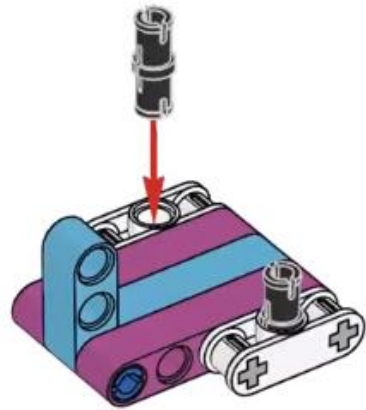

8



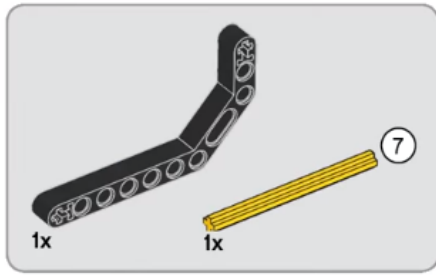

9

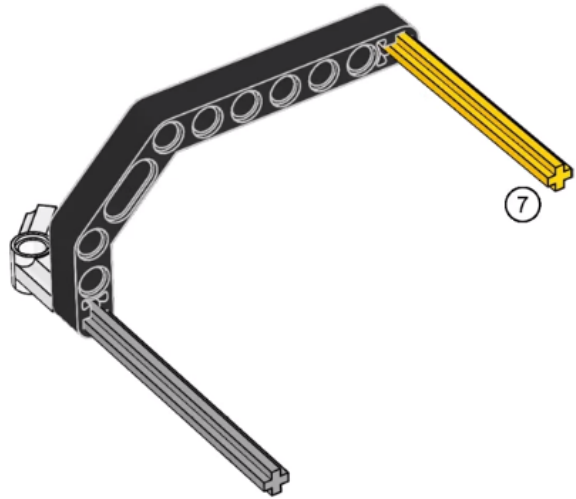

10

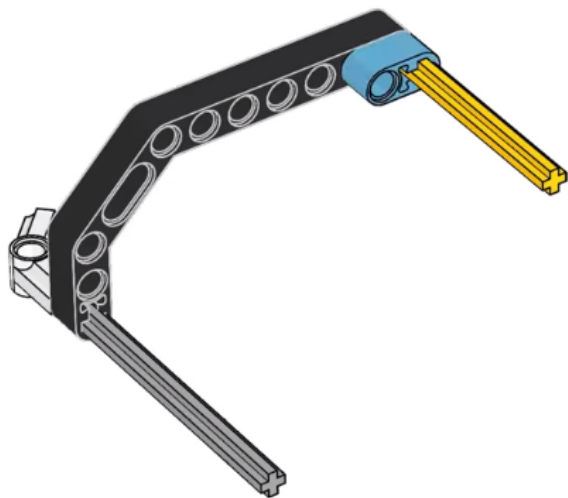



11

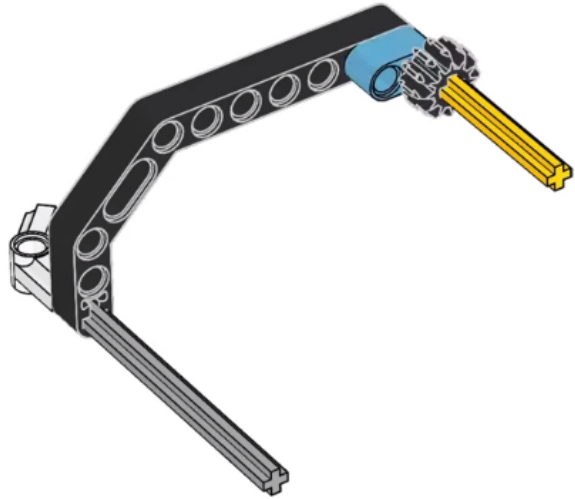

12

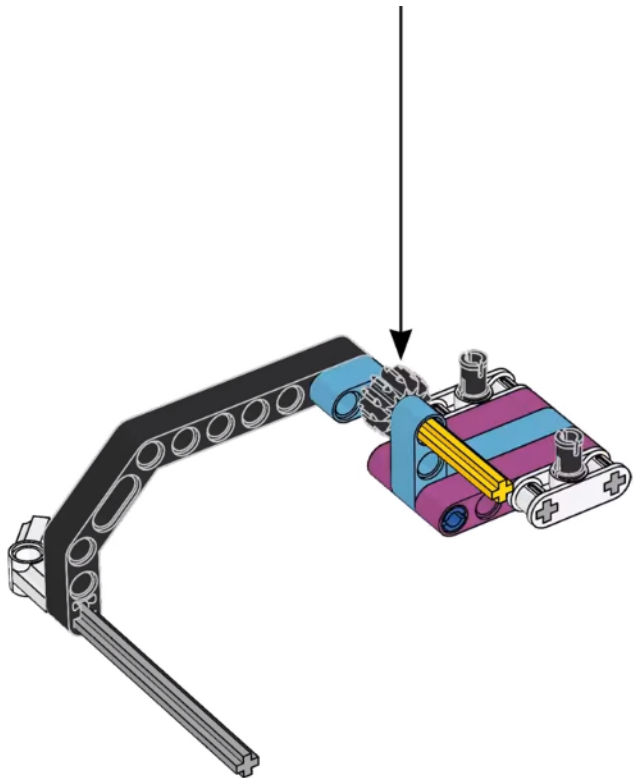



13

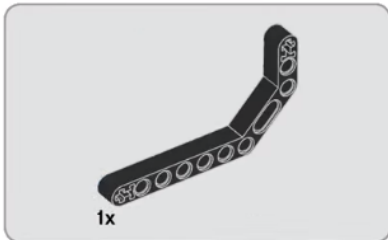
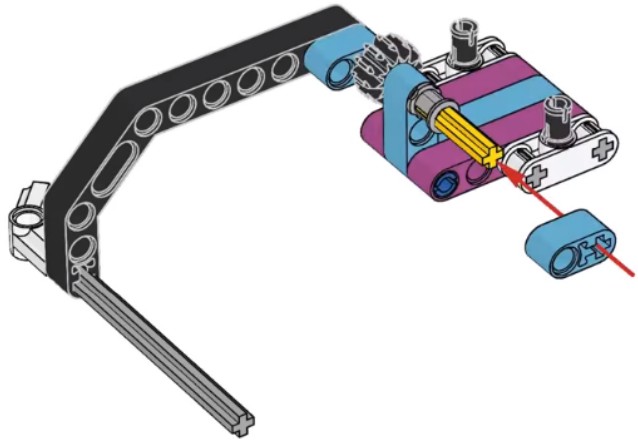

14

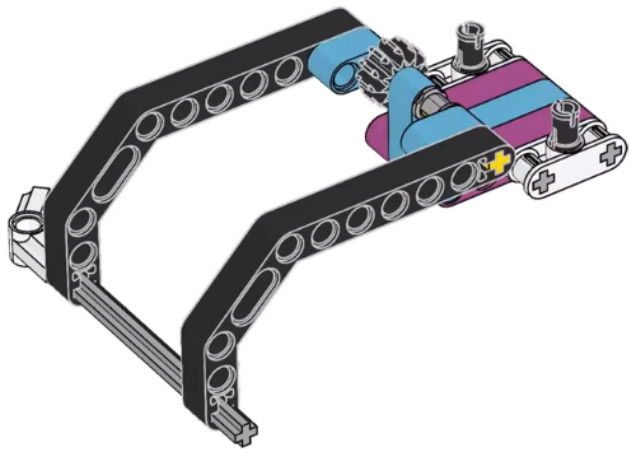



15

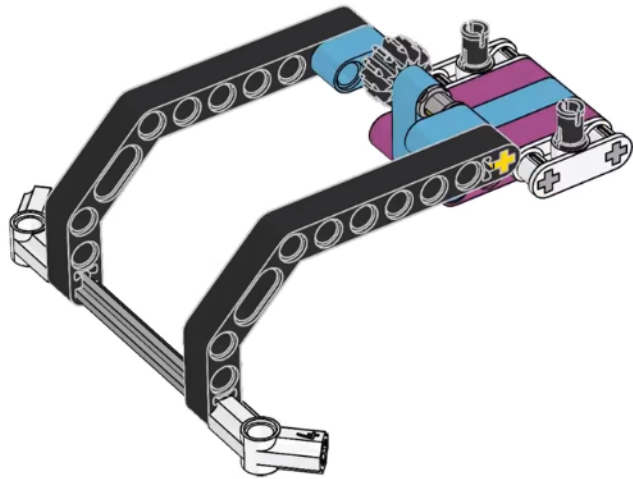

16

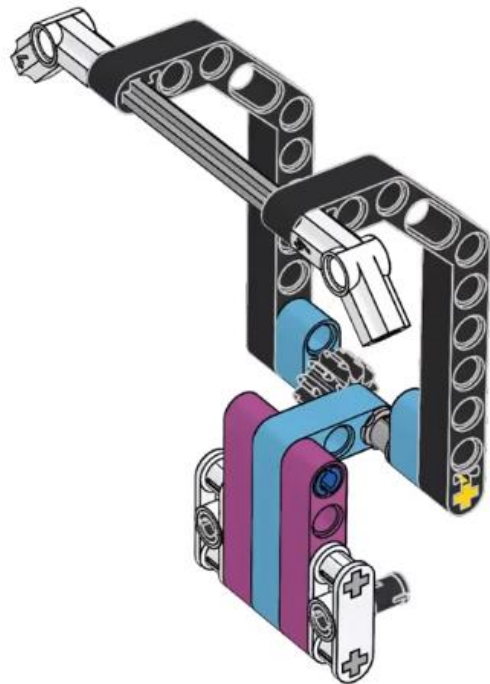

17

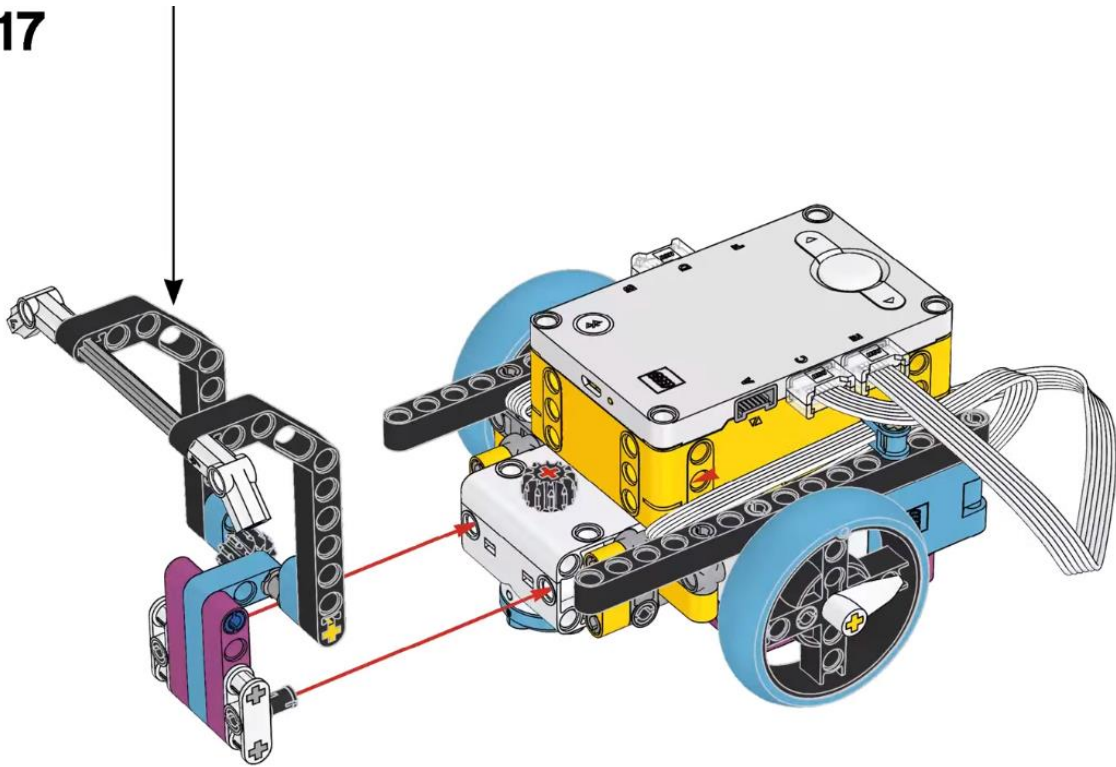

18

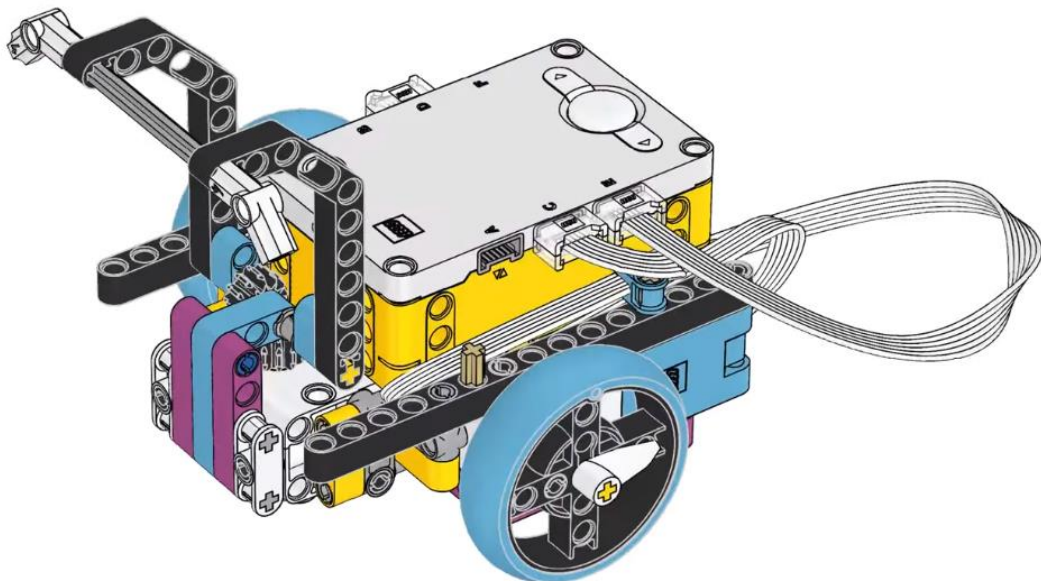

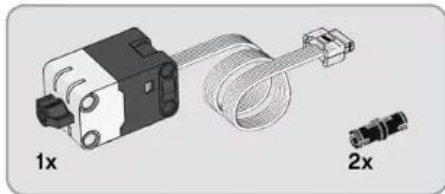

19

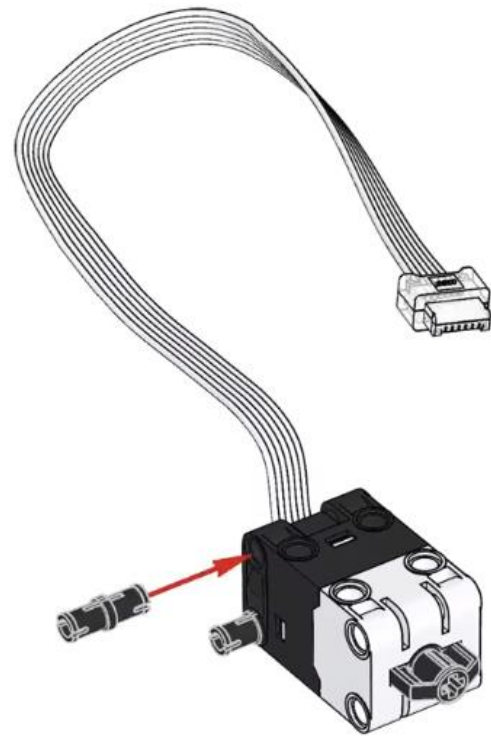

20

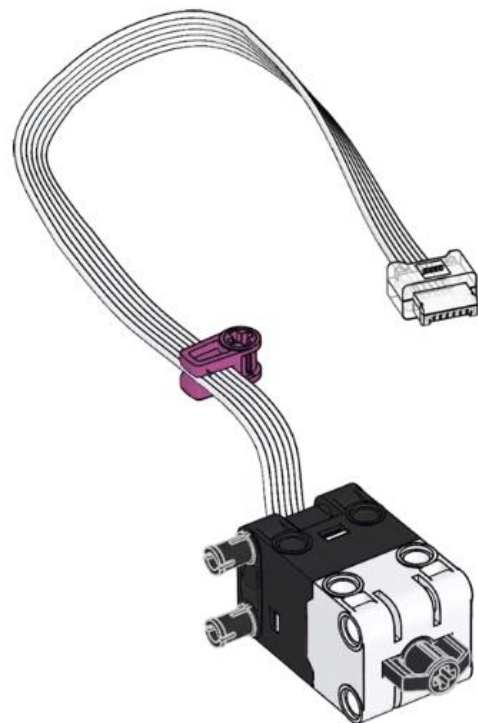

21

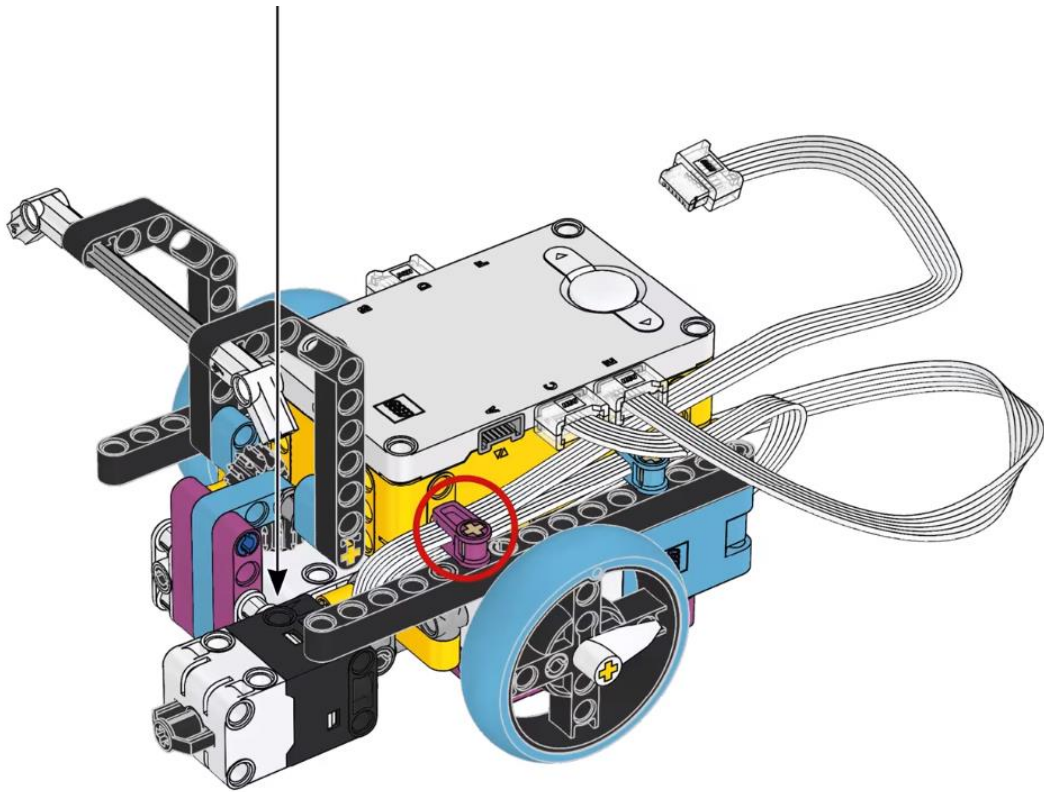

22

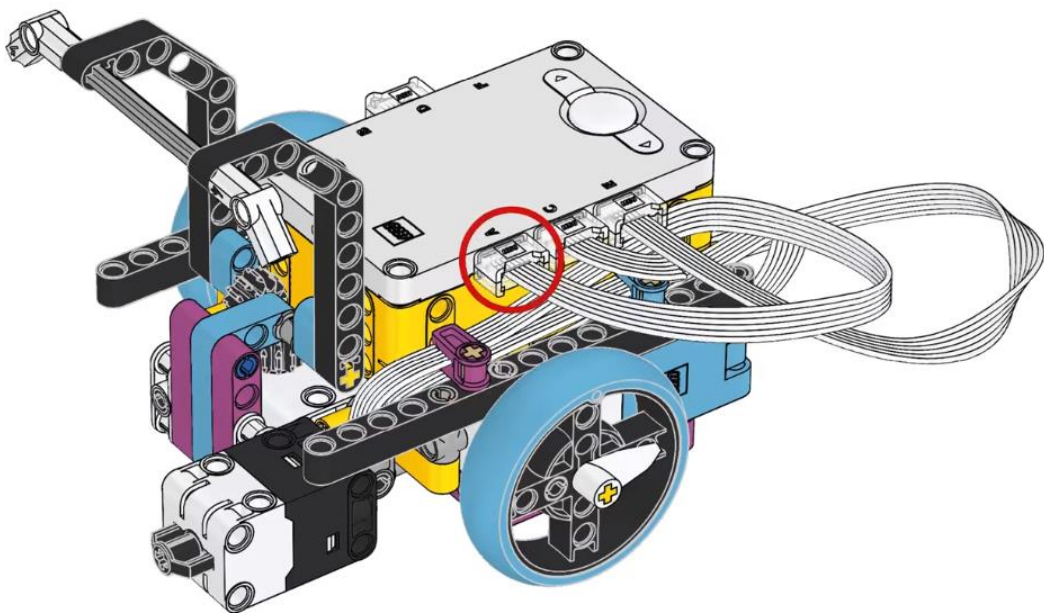

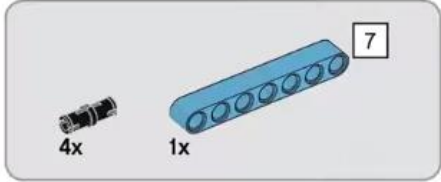
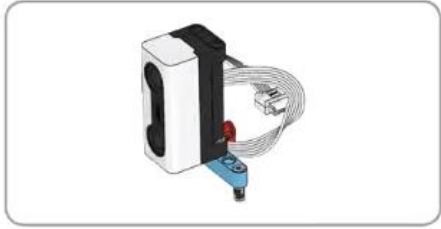

23

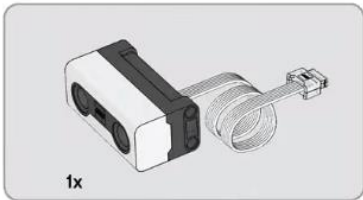
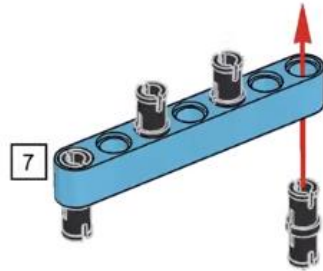

24

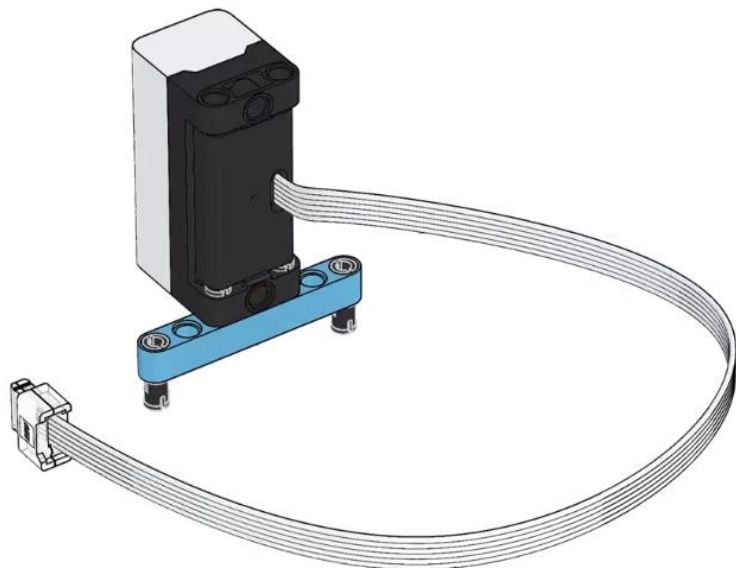



25

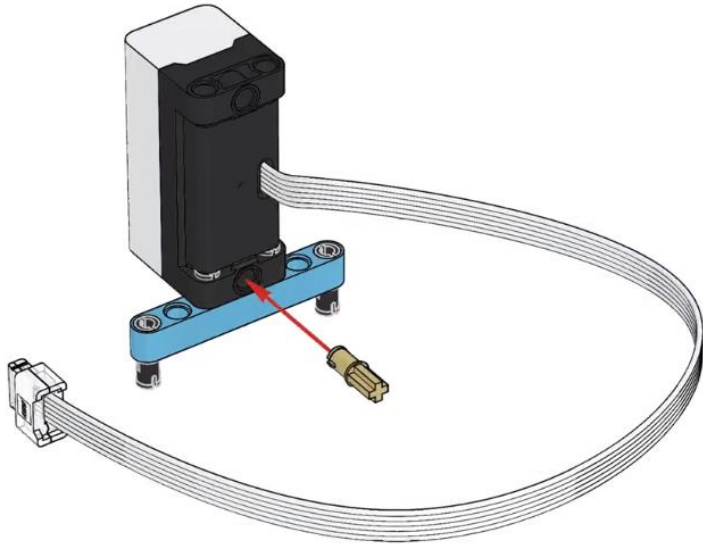

26

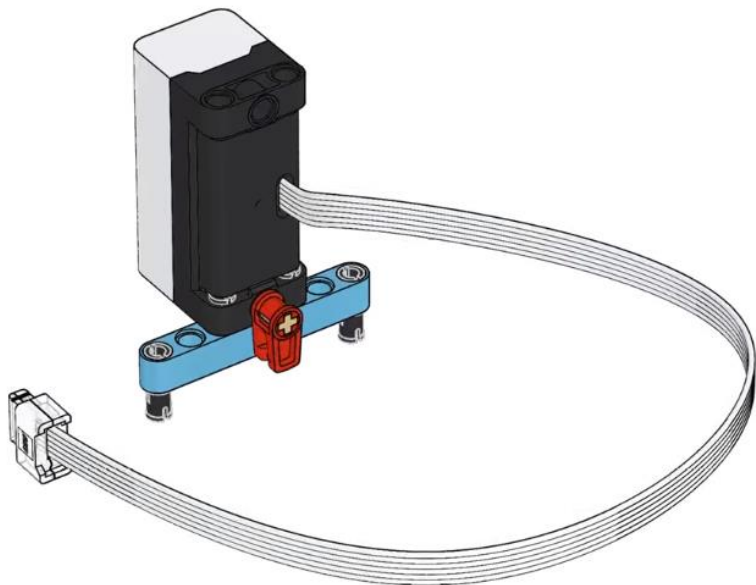

27

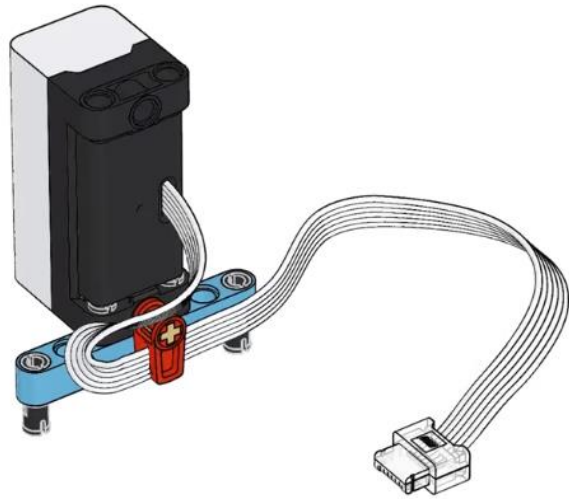

28

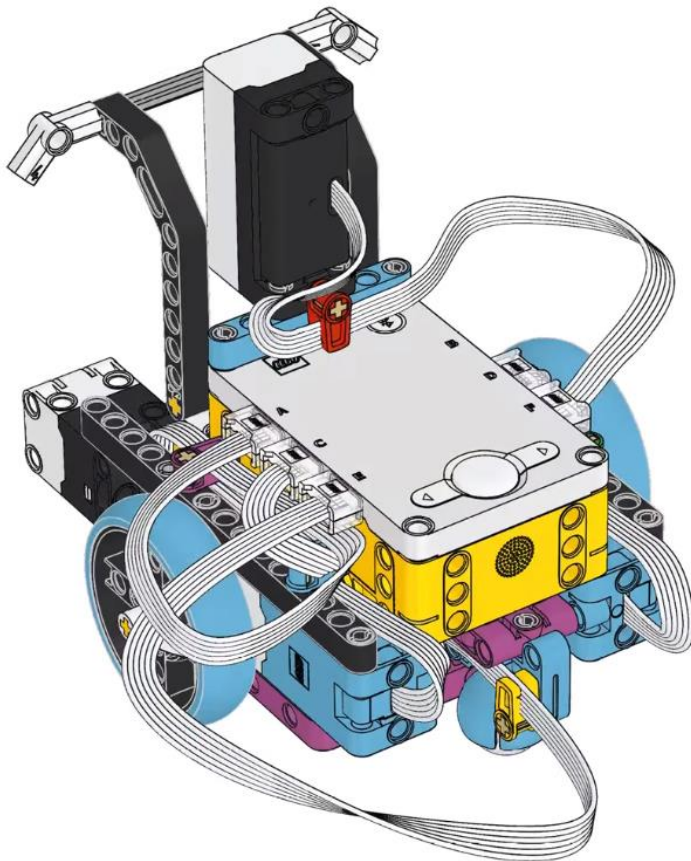

29

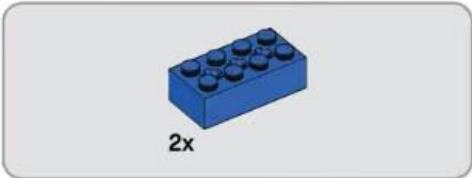
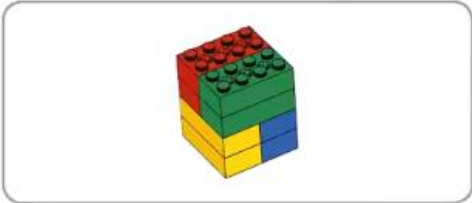
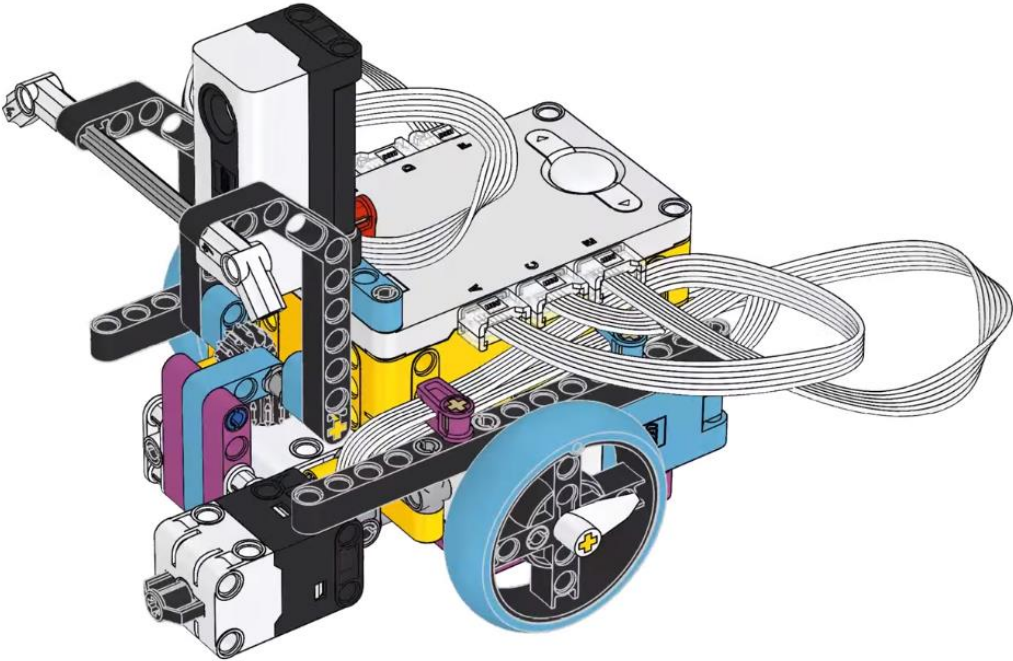

30

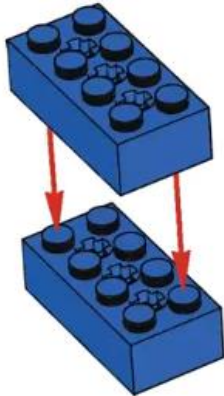

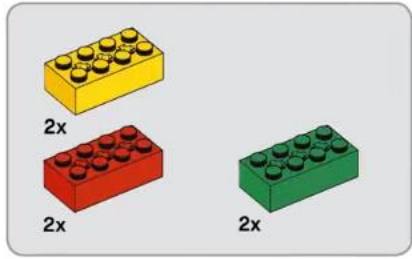

31

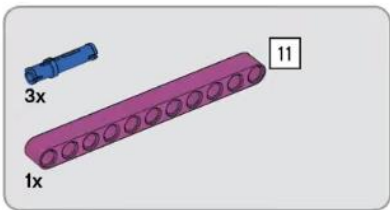
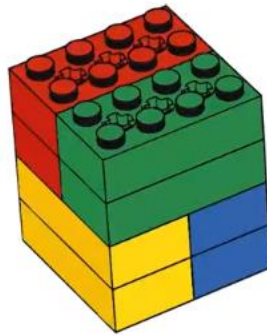

32

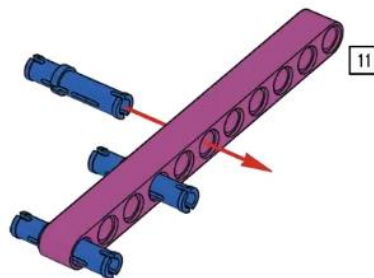

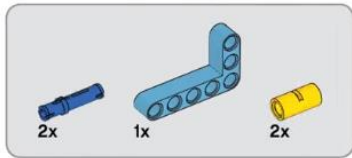

33

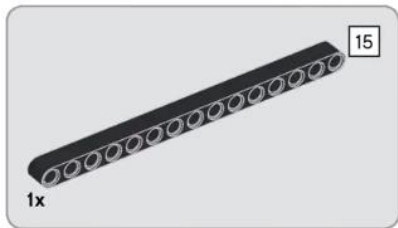
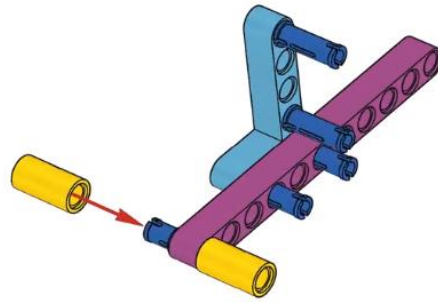

34

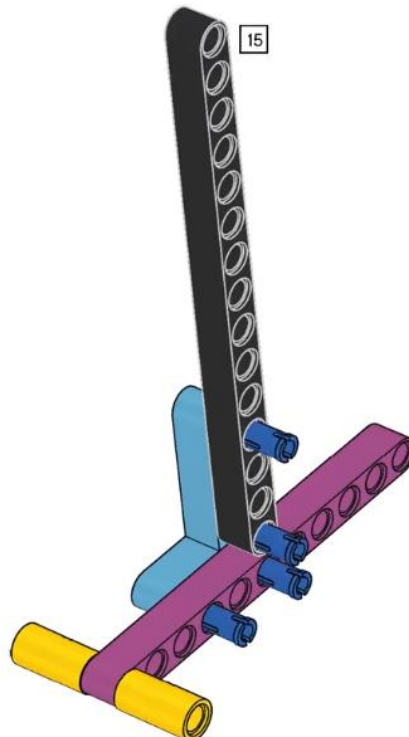

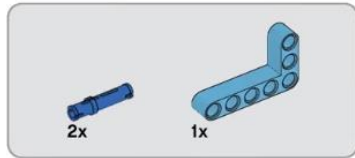

35

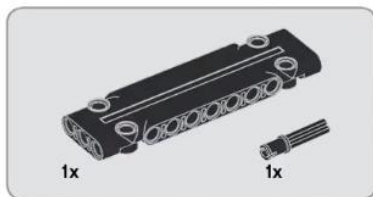
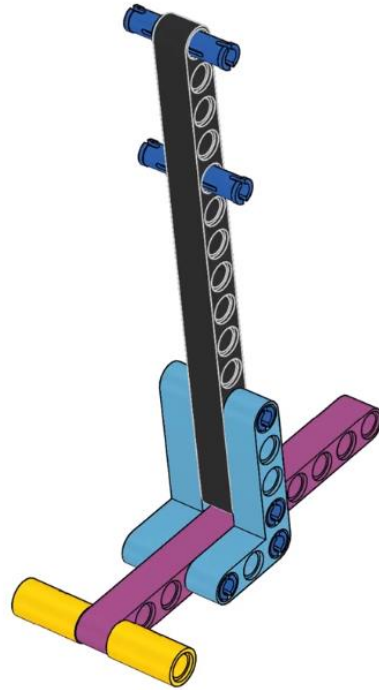

36

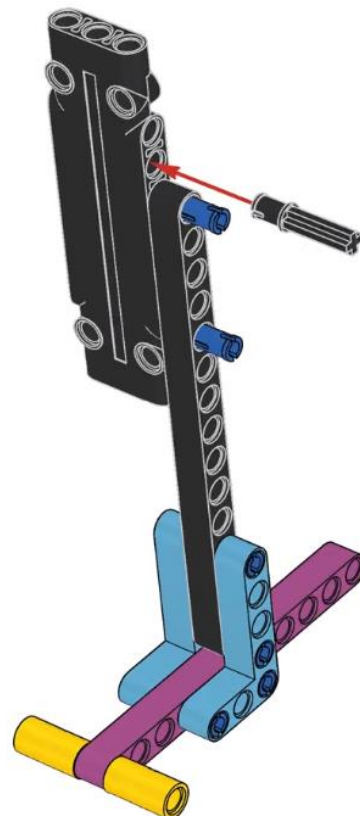

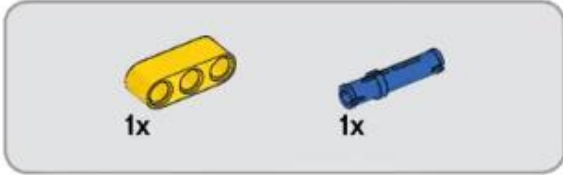

37

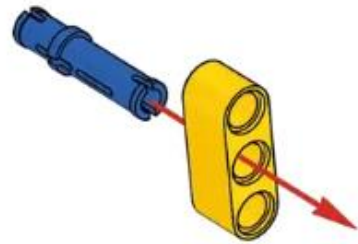

38

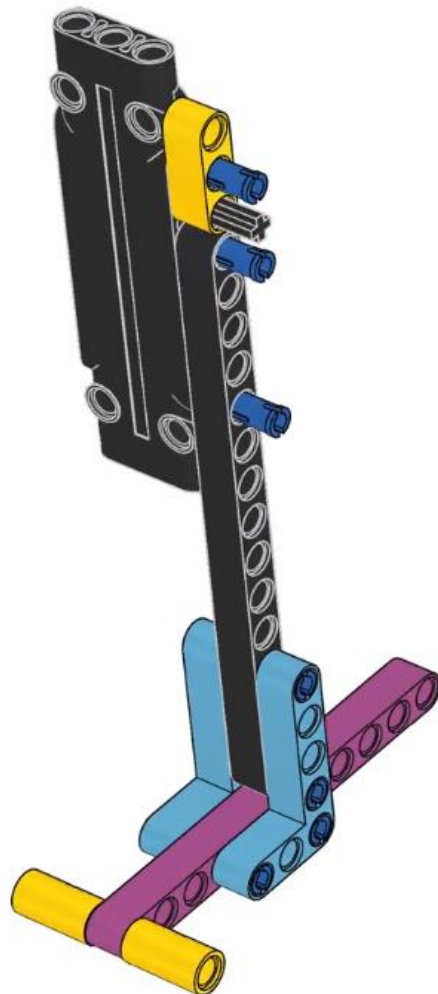

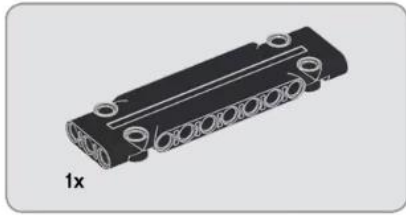

39

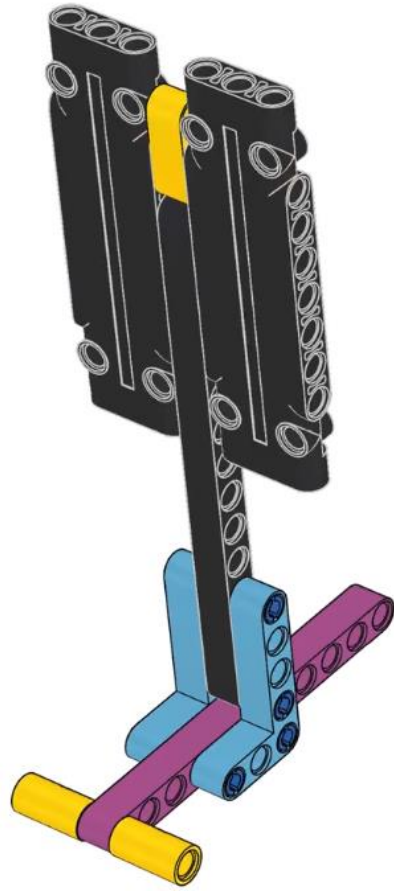

40

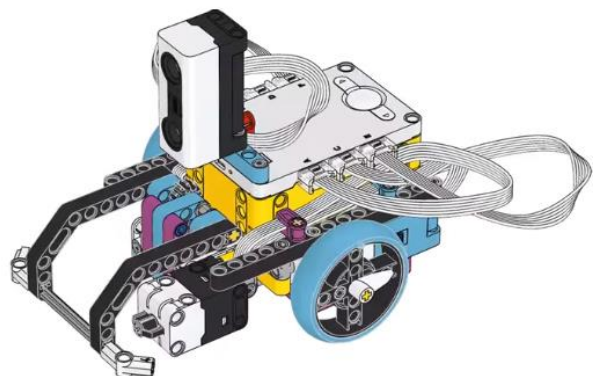
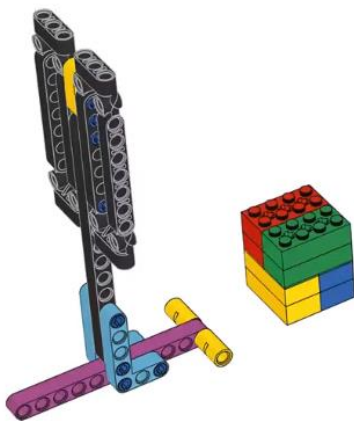

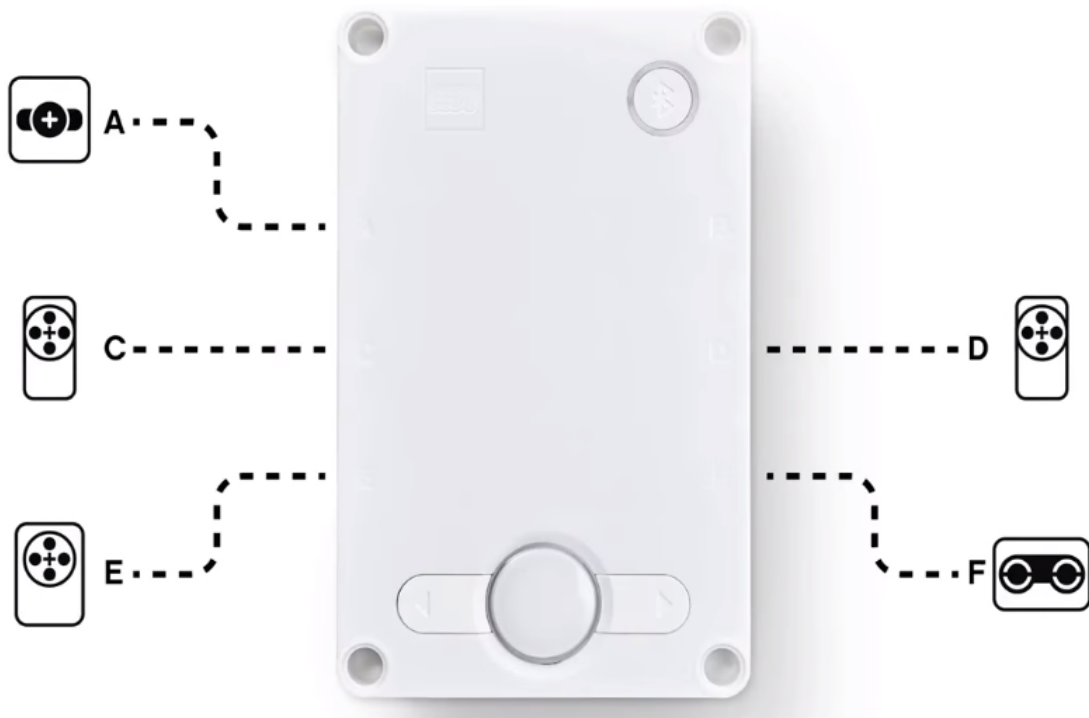

Codificación

En este ejercicio vamos a trabajar con sensor de infrarrojos.

El motor que mueve el brazo lo fijamos a una potencia del 25%.

Como queremos que el brazo baje lo pondremos en marcha en sentido contrario de las agujas del reloj durante 45°.

Fijamos como motores de movimiento C+D.

Fijamos una potencia del movimiento del 20%.

Marchamos en línea recta.

Hasta que nuestro sensor ultrasónico detecte un objeto a menos de 8 cm.

A continuación paramos movimiento.

Inicializamos el ángulo de guiñada.

Empezamos a movernos derecha 100 (Rotación sobre sí mismo)

Esperamos que el ángulo de guiñada sea mayor de 89.

Paramos el movimiento.

El motor E que controla el brazo lo movemos en sentido de las agujas del reloj 45°.

Los motores de movimiento en línea recta durante 15 cm.

El motor E lo movemos en sentido contrario de las agujas del reloj 45°.

Los motores de movimiento retrocedemos 10 cm.

Inicializamos de nuevo el ángulo de la guiñada.

Movemos los motores de movimiento derecha 100 rotación sobre sí mismo.

Esperamos hasta que el ángulo de guiñada sea mayor a 44°.

Con los motores de movimiento avanzamos durante 15 cm.

Con el motor E giramos en sentido de las agujas del reloj 45°.

Con los motores de movimiento retorremos durante 10 cm.

El resultado final lo podrás ver en el siguiente vídeo.



En la siguiente página tienes el código completo.

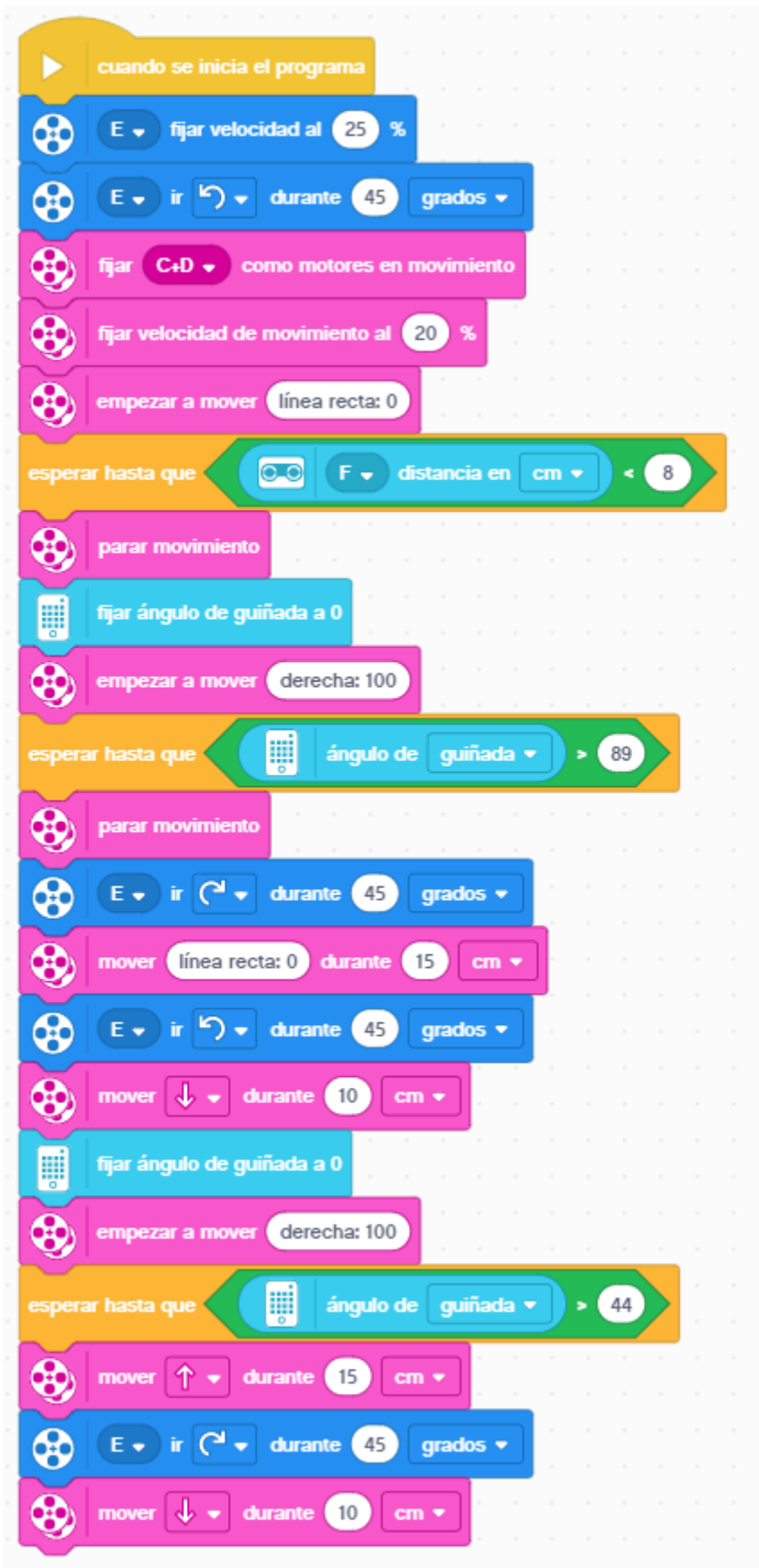

En este ejercicio vamos a trabajar con el sensor de presión.
Fijamos al motor E una potencia de 25% (Motor que mueve el brazo).
Fijamos como motores de direcciones C+D.
A los motores de dirección de damos una potencia de 20%.
Nos empezamos a mover en línea recta.
Esperamos hasta que nuestro sensor de presión detecte un contacto.
Paramos el movimiento.
Retrocedemos un segundo.
Inicializamos el ángulo de guiñada.
Empezamos a movernos a la derecha 100 (Rotación sobre sí mismo).
Esperamos que el ángulo de guiñada sea mayor a 80.
Paramos el movimiento.
Nos movemos hacia enfrente 10 cm.
El motor E (que mueve el brazo) lo movemos en sentido contrario de las agujas de reloj 45°.
Volvemos a inicializar el ángulo de guiñada.
Nos movemos derecha 100 (Rotación sobre sí mismo).
Esperamos que el ángulo de guiñada sea mayor a 135.
Paramos el movimiento.
Nos movemos hacia adelante 10 cm.
Movemos el motor E (El que mueve el brazo) en sentido de las agujas del reloj 45°.
Nos desplazamos hacia atrás 10 cm.

El siguiente código QR podrás ver el movimiento del robot.



En la siguiente página está el código:

